

Lo-Carbon Sentinel Kinetic Horizontal

Features & Benefits

- Manufactured in the UK
- Building Regulations ADF compliant
- Recognised in SAP PCDB
- Energy Savings Trust best practice compliant
- Up to 81% heat recovery whilst controlling condensation
- Programmable Summer bypass
- Digital controller for simple and accurate commissioning
- External condensate connection
- Plug and play controls; Humidistat, Ventwise, Wireless remote
- LS inputs (Light Switch)
- Volt-free inputs



The Sentinel Kinetic Horizontal Range

A wholehouse heat recovery system with up to 81% heat exchange efficiency. An easily accessible heat recovery cube protected by two removable G3 filters. Two Lo-Carbon Energy Saving EC/DC fans ensure long life (typically over double the life of AC motors) and lowest possible energy use. Fully insulated construction with built-in condensation drain. Specifically designed for new build constructions with a high level of insulation.

Lo-Carbon Sentinel Kinetic Horizontal meets the latest requirements of the Building Regulations ADF for wholehouse system ventilation: System 4. Continuous mechanical supply and extract with heat recovery. Each model has three fully adjustable speeds and a purge setting (maximum flow). Supplied with the unit is a digital controller that can be used to pre-set the speeds to any required airflow within the performance range.

Integral Humidity Sensor

The integral humidity sensor ('H' models) increases speed in proportion to relative humidity levels, saving energy and reducing noise. The sensor also reacts to small but rapid increases in humidity, even if the normal trigger threshold is not reached. This unique feature ensures adequate ventilation, even for the smallest wet room. The night time relative humidity setback feature suppresses nuisance tripping as humidity gradually increases with falling temperature. Acoustically lined - low noise levels from only 20dB(A) @ 3m.

Models

Model	Stock Ref
Kinetic 200ZPH	407162
Kinetic 200ZH	449540
Kinetic 300ZH	449536
Kinetic 200ZMH	448778

Optional Controls

Model	Stock Ref
Wireless Enable Kit (includes one switch)	441865

Wireless Boost Switch (max 3 switches)	437827
Ventwise Controller (also requires sensors: see Accessories & Controllers section)	441780

Accessories

Model	Stock Ref
Spare Filters Kinetic 200Z/ZH (2 pack)	449524
Spare Filters Kinetic 300ZH (2 pack)	449575
Spare Filters Kinetic 200ZMH (2 pack)	449524

Multiple Control Options:

Five Volt-free pairs of switch terminals for sensor inputs allow boosting from a full range of Vent-Axia controllers - humidistats, PIR, timers.

Two terminals with 0-24V outputs allow 0V to 10V proportional control by sophisticated controllers such as CO₂ sensors and proportional humidistats.

The optional Ventwise controller senses temperature rise in a bath/shower hot water supply and/or current in a cooker/hob electrical circuit to activate boost, ensuring additional ventilation when needed. Switch-live for boosting via light switches (220-240V AC) or manual Normal/Boost switches. This connection has the advantage of Delay-On and Delay-Off facility. Delay-On enables you to prevent the Boost airflow between 0 and 10 minutes after a light switch has been activated. Delay-Off allows the Boost airflow to continue after a light switch is turned off to ensure effective clearance of humidity. This timer is adjustable between 0 and 25 minutes.

Summer Bypass

An internal damper operates when the external temperature is below the internal temperature, and the internal temperature is too high.

The bypass opens and allows the cooler outside air to help cool the dwelling.

Normal mode: Fans run on Normal speed with bypass open until the internal dwelling temperature falls below the set 'Indoor' (maximum desired) temperature.

Evening Purge mode: The fans run on Boost speed until the internal temperature falls below the set 'Indoor' temperature. If, after five hours the internal temperature is still above the set 'Indoor' temperature, the unit will switch down to normal speed for the remainder of the 'bypass open' period.

NightTime Purge mode: As Evening Purge, except that the unit will continue on Boost speed until the internal air temperature reaches the 'Outdoor' temperature set point (Default 14°C). This mode gives pre-cooling of the dwelling for the following day.

In Evening and Night Time Purge modes, the user can turn off the boost function by pressing the Boost button.

Frost Protection

In cold climates there is a possibility of frost building up on the intake side of the heat exchanger. In order to prevent damage, the Kinetic reduces supply flow while maintaining extract flow at temperatures down to -20°C.

SEC Class Rating

Model	SEC Class
Kinetic 200ZH/ZPH/ZMH	A
Kinetic 300ZH	A

SAP PCDB Test Results

200ZPH		
	Thermal Efficiency %	SFP (W/l/s)
K+1	86	0.62
K+2	84	0.65
K+3	83	0.76

200ZH/ZMH		
	Thermal Efficiency %	SFP (W/l/s)
K+1	80	0.69
K+2	81	0.70
K+3	80	0.80
K+4	80	0.97
K+5	79	1.14

300ZH		
	Thermal Efficiency %	SFP (W/l/s)
K+1	77	0.59
K+2	78	0.51
K+3	78	0.57
K+4	78	0.66
K+5	78	0.76
K+6	78	0.88
K+7	77	1.05

Dimensions (mm)

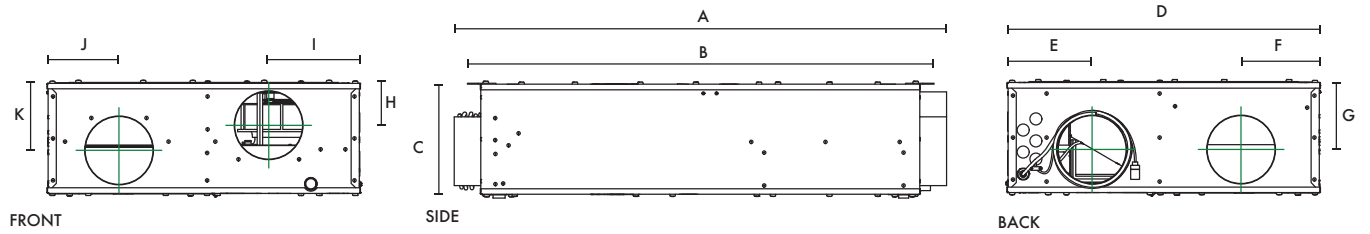

Model	A	B	C	D	E	F	G	H	I	J	K	Spigots Ø
200ZH	895	849	200	570	155	144	122	76	167	131	122	125
300ZH	985	940	301	720	184	179	187	102	279	174	187	150

Weight: 200ZH - 26kg, 300ZH - 38kg

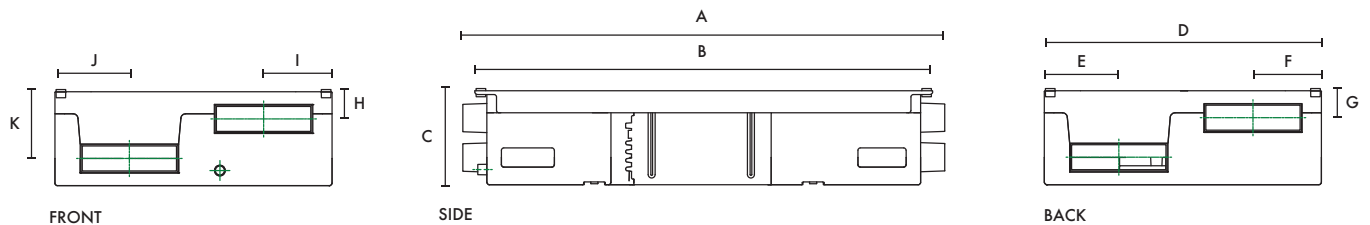

Model	A	B	C	D	E	F	G	H	I	J	K	Spigots
200ZPH	1000	950	200	575	155	142	60	61	142	154	143	204x60
200ZMH*	895	849	200	570	195	140	54	66	168	138	143	204x60

Weight: 200ZPH - 14kg, 200ZMH - 26kg

*Galvanized steel outer case construction

Performance - 200ZH/ZMH/ZPH Model

Fan speeds are fully adjustable within the performance range.

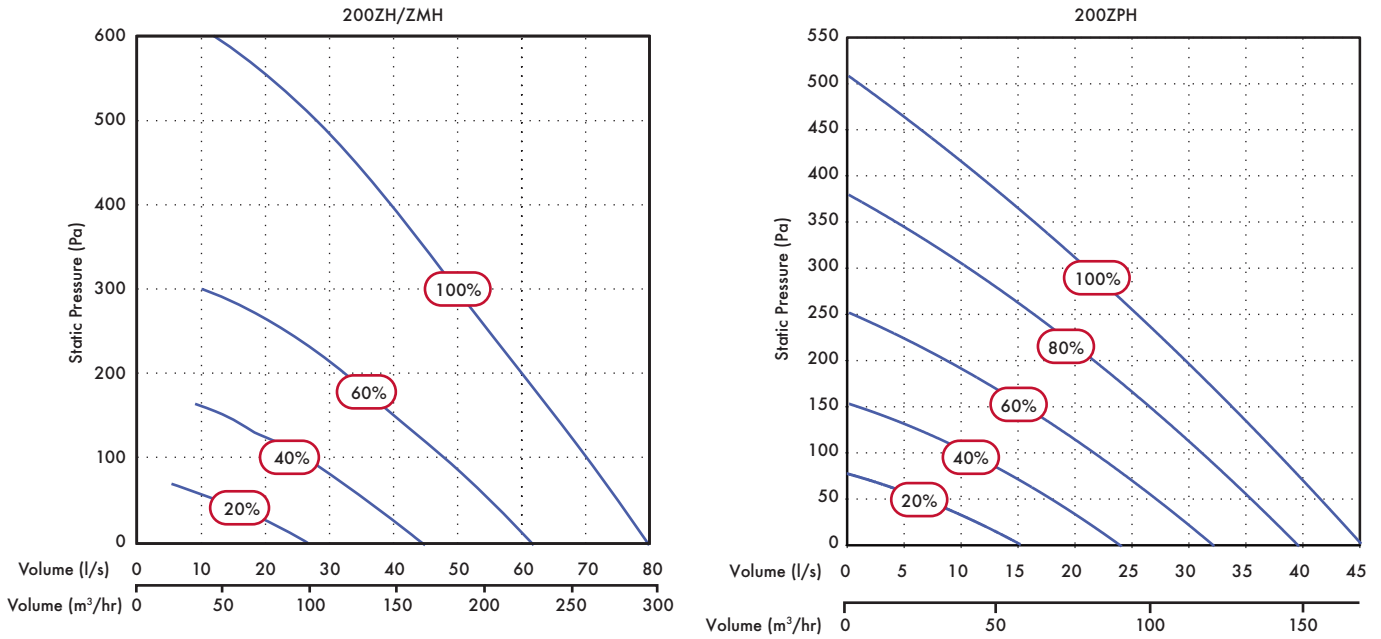

Sound Data - 200ZH/ZMH Model

Flow %	Test mode	63	125	250	500	1k	2k	4k	8k	dB(A) at 3m
20	Supply	50.3	54	50.1	45.5	37	36	27.5	31.1	30.0
	Extract	47.2	47.7	46.6	41.8	30.7	27.9	24.6	30.5	26.3
	Breakout	48.8	55.8	51.2	43.8	32.4	29.0	25.4	30.8	26.8
40	Supply	52.7	61.7	60.1	61.8	47.4	45.1	38.1	40.1	42.7
	Extract	50.7	55.4	55.0	51.5	37.5	34.6	25.9	30.7	33.9
	Breakout	53.7	60.1	61.1	50.7	40.2	35.8	27.1	30.3	34.0
60	Supply	52.8	64.5	66.7	59.4	51.1	51.1	42.9	39.3	44.0
	Extract	50.6	59.0	62.1	57.1	43.7	40.0	29.0	31.6	39.7
	Breakout	55.1	64.4	66.8	57.5	47.0	41.4	32.0	32.0	39.7
100	Supply	58.3	69.2	68.6	64.6	56.9	56.1	47.9	45.6	48.1
	Extract	51.8	63.1	64.9	63.9	52.4	45.9	34.8	34.8	45.2
	Breakout	59.4	68.1	69.7	68.3	53.1	47.1	36.5	34.3	46.5

Sound Data - 200ZPH Model

Speed	Test mode	63	125	250	500	1k	2k	4k	8k	dB(A) at 3m
20%	Breakout	48.3	41.3	37.7	35.8	34.5	28.2	26	31.2	21.5
	Supply	39.6	37.1	36	32.9	30.6	22.9	24.9	29.4	23.1
	Extract	49.4	40.7	35	30.4	26.3	22.5	23.6	30.1	20.8
40%	Breakout	47.8	42.2	46.7	40.6	40.2	34.2	28.1	31.2	25.3
	Supply	45.7	38.3	40.7	39	38.1	28.7	24.9	28.5	28.1
	Extract	50	45.5	39.9	37	34.3	28.6	25.1	30.6	24.3
60%	Breakout	54.4	51.2	53.8	46.2	43	38.9	33.8	32	29.7
	Supply	46.1	49.2	45.3	44.4	42.4	35.2	27	29.3	32.7
	Extract	49.5	41.9	45.4	41.7	39.4	35.2	27.6	30.3	27.7
80%	Breakout	50.4	51.2	56.7	53.9	48.5	43.2	39.9	34.9	34.5
	Supply	52.9	48.9	47.5	51.3	47.2	40.8	31.2	30	36.8
	Extract	48.9	43.3	46.8	50	42.4	38.6	31.3	30.1	32.2
100%	Breakout	49.3	49.8	52.9	54	51	46.3	41.2	35.7	35.1
	Supply	43.8	45.8	50.7	56.3	50	44.3	35.7	29.7	38.2
	Extract	53.2	46.9	48	52.8	45.4	42.1	35.1	30.5	34.9

Performance - 300ZH Model

Fan speeds are fully adjustable within the performance range.

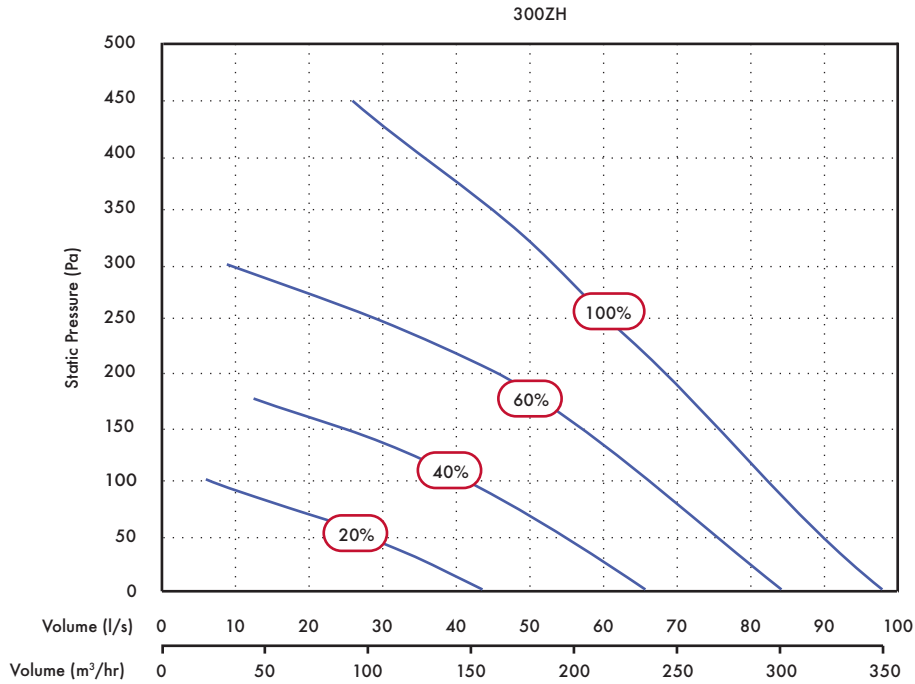

Sound Data - 300ZH Model

Flow l/s	Flow %	Test mode	63	125	250	500	1k	2k	4k	8k	dB(A) at 3m
26	10	Supply	42.5	42.8	38.3	32.9	28	24.6	25.5	30.3	26.3
		Extract	46.9	45	40.3	34.4	27.4	23	24.3	30.1	22.5
		Breakout	48.7	52.1	47.7	40.5	32.9	27.3	25.1	31.6	24.4
44	20	Supply	45.6	47	41.7	35.7	31.7	26.7	24.8	30	29.9
		Extract	46.9	48.6	47	38.2	29.5	25.3	23.8	29.9	25.3
		Breakout	50.2	56.4	53.9	46.3	37.5	32.5	25.2	31.4	28.8
55	30	Supply	44.4	46	52.9	39.4	35.1	31.9	25.5	30.5	33.9
		Extract	47	48	55.5	42.5	32.2	29.9	25.7	30.6	30.6
		Breakout	52.2	59.6	62	51.4	41.9	37.4	28.1	31.4	34.7
66	40	Supply	43.1	44.4	54.3	43.5	39.2	35.7	27.7	29.9	35.0
		Extract	48.9	49	58.4	45.9	35.7	33.4	25.3	29.9	33.4
		Breakout	54.6	58.3	66.1	52.6	39.3	36.5	31.1	35.3	37.7
85	60	Supply	44.7	49.8	58	50.4	45	41.9	30.6	30.3	39.1
		Extract	51	53.6	61.2	50.1	41.6	40.1	30.7	31.1	36.7
		Breakout	57.5	62.6	68.7	57.5	45.9	41	36.3	34	40.7
96	80	Supply	46	52.2	57.1	56.5	47.2	44.2	32.3	30.5	40.5
		Extract	55.5	55	63.1	53.4	44.3	41	33.5	31.4	38.8
		Breakout	62.2	65.7	68.8	63	50.8	43.8	38.8	35.4	42.9
98	100	Supply	46.6	52.3	57	55.4	47.1	43.7	32.1	30.3	40.1
		Extract	53.7	55.2	63.3	53.3	44.1	41.2	33.2	31.5	38.9
		Breakout	62.2	73.8	77.4	74.1	67.4	61	53.6	45.4	53.9

Tested according to BS848. Breakout quoted spherical. Supply and Extract quoted hemispherical.

Consultants Specification

Operation

The supply and extract ventilation unit shall be as Sentinel Kinetic Z as manufactured by Vent-Axia and shall be sized as indicated on the drawings and shall be in accordance with the particular specification; 200Z - 200mm deep, 300Z - 300mm deep.

The Sentinel Kinetic Z shall automatically vary the ventilation rate via EC/DC motors, as it receives signals from one of the optional interconnected sensors. When a signal is received, the fans shall either vary their speed proportionally or on a trickle and boost principle.

The unit shall have the facility to commission the supply and extract fans individually via the wired remote control unit. The fans themselves shall have independent, infinitely variable speed control.

Unit Specification (200Z/ZM, 300ZH)

The unit shall be manufactured with a galvanized steel outer case construction and shall have a high efficiency aluminium heat exchanger.

Unit Specification (200ZP)

The unit shall be manufactured with high density EPP case and shall have a high efficiency polymer heat exchanger.

The unit shall have supply and extract filters, automatic summer bypass, integral minimum and maximum infinitely variable speed controls with failure indication via the wired remote controller.

The unit shall have low energy, high efficiency EC/DC fan/motor assemblies with sealed for life bearings. The impellers shall be high efficiency backward curved centrifugal type.

The unit shall have a heat exchanger cell with a thermal efficiency of up to 81% when tested to EN 308. This shall be protected by G3 grade synthetic filters on supply and extract. Complete with a condensate drip tray and drain connection.

The unit shall be constructed with a removable access panel allowing full maintenance access from below. The removable panel shall provide access to the following:

- ✓ Supply or extract fan
- ✓ Supply and extract filter
- ✓ Heat exchanger
- ✓ Access to the electrical connections

Access shall be provided for wiring termination and setup/commissioning.

Standard Controls

All Sentinel Kinetic Z units shall incorporate the following functions integrally mounted, pre-wired and factory fitted by the manufacturer:

- ✓ Infinitely variable fan speed control on supply and extract
- ✓ Min/max ventilation control/set point
- ✓ Heating interlocks
- ✓ 0-10V proportional speed adjustment
- ✓ Volt free contacts
- ✓ 24V sensor supply
- ✓ On/off or trickle boost function from remote switch, e.g. PIR occupancy detector
- ✓ The unit shall be controlled by the 'Sentinel' control devices (enablers and sensors) as detailed in the schedule or on the drawings
- ✓ Fully automatic summer bypass
- ✓ Switched Live input with adjustable 'delay-on' feature

- ✓ Fan failure or component failure indicated via individual fault code display
- ✓ Running time counter
- ✓ Control panel PIN number lock
- ✓ Automatic frost protection effective to -20°C
- ✓ The unit shall incorporate ('H' models) an integral humidity sensor with the following features:
 - Ambient Response: Raises the humidity trigger point as dwelling temperature reduces
 - Rapid Response: Monitors the rate of change in humidity and triggers increased airflow even if the humidity trigger threshold is not reached
 - Proportional Response: Incrementally increases the fan speed to reduce noise and reduce energy consumption

The unit shall be controlled by the 'Sentinel' control devices (enablers and sensors) as detailed in the schedule or on the drawings.

Mounting Option



Slab

Airflow Direction

View from beneath (drawing for airflow demonstration only - not intended to be an accurate representation of the product)

View from beneath

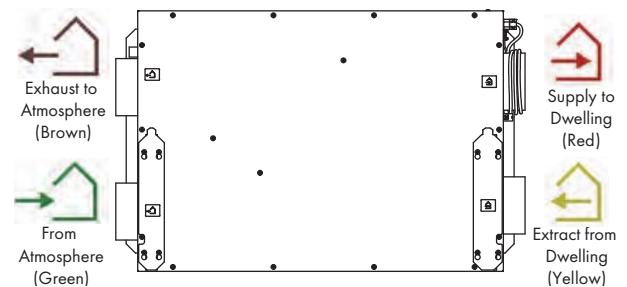

Electrical Connection

Please note: Electrical connection should be carried out by an appropriately qualified person and in accordance with current wiring regulations.

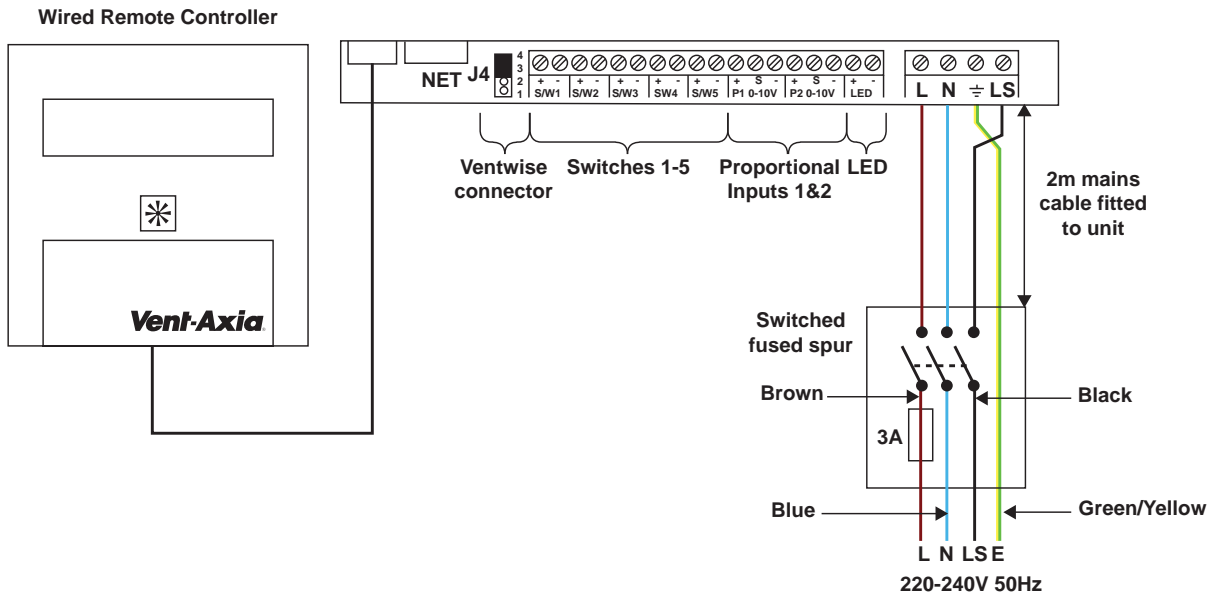

Trickle to Boost by two lighting circuits or Trickle/Boost switch

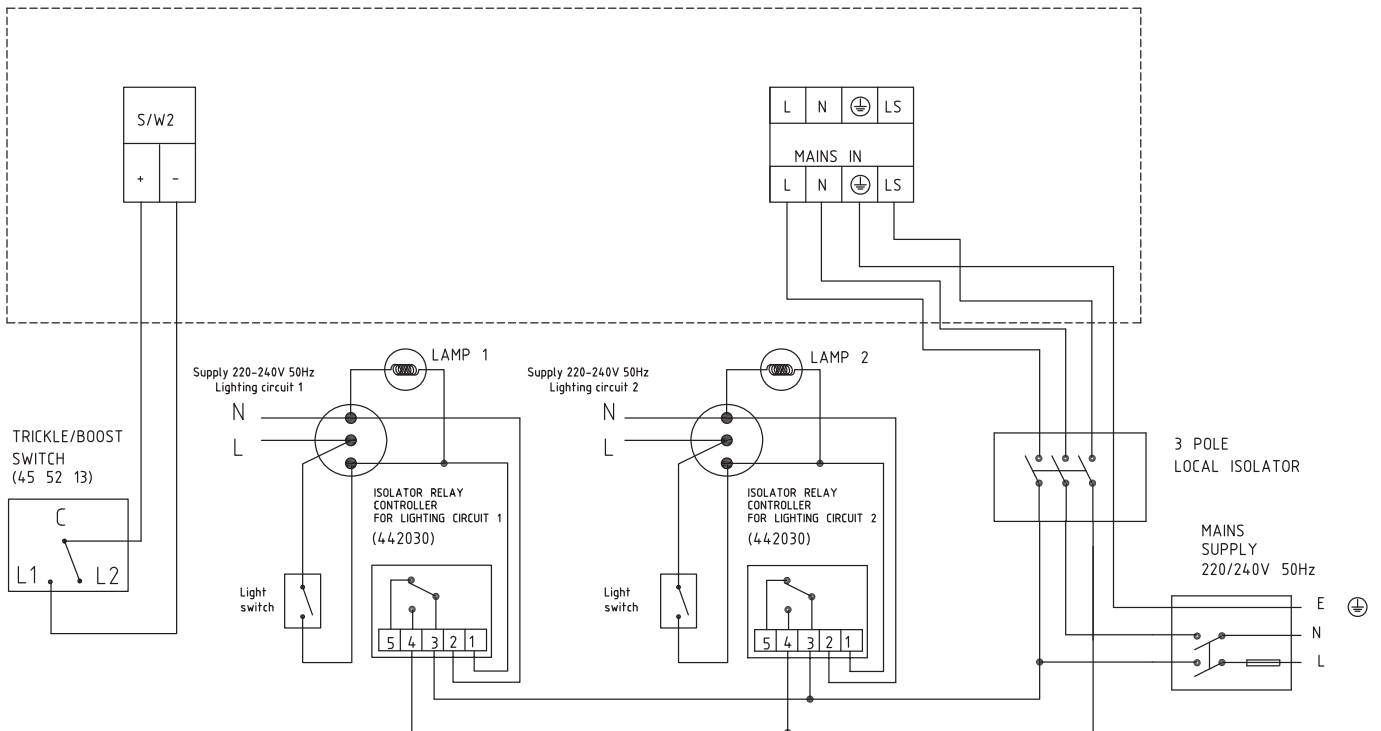

BPC Ventilation Ltd
8 Redlands Road
Larne
BT40 1AX

T: 028 2827 5150

E: info@bpcventilation.com

W: www.bpcventilation.com