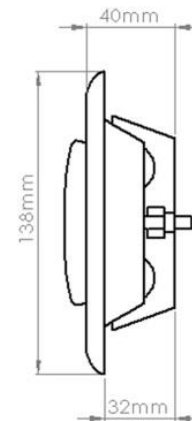
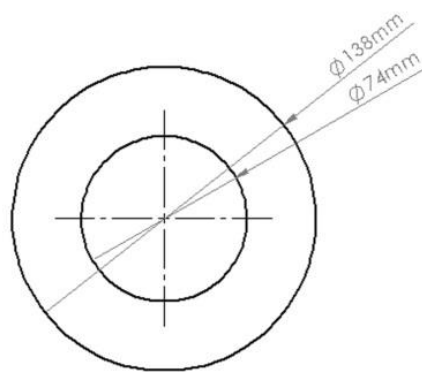

PRODUCT DATA SHEET

MW104FRE

FIRE RATED EXTRACT VALVE

W RAL9010

SPECIFICATION DETAILS

The MW104FRE 100mm diameter Round Fire Rated Extract Valve is manufactured from White Epoxy Powder Coated Steel. The valve has a male spigot to fit inside the System 100 duct.

The MW104FRE Extract Air Valve is fully adjustable and has a locking nut to fix the position of the control disc upon commissioning. It is supplied complete with a fixing body with pre-drilled holes for installation.

The MW104FRE incorporates an integral intumescent material and has been fire tested to BS EN 1365-2: 1999 with 60 minute rating for ceilings.

MW104FRE has been designed for use with Verplas System 100 Round.

| | |
|---------------------------|--------------------|
| Manufacturer: | Verplas Ltd |
| Part Number: | MW104FRE |
| Size: | 100mm Diameter |
| For use with: | Verplas System 100 |
| Box quantity: | 7 |
| Individual Weight: | 272g |
| Colour: | Silver |

MAX/MIN OPERATING TEMPERATURES

+ 60°C to - 15°C

PERFORMANCE CURVE

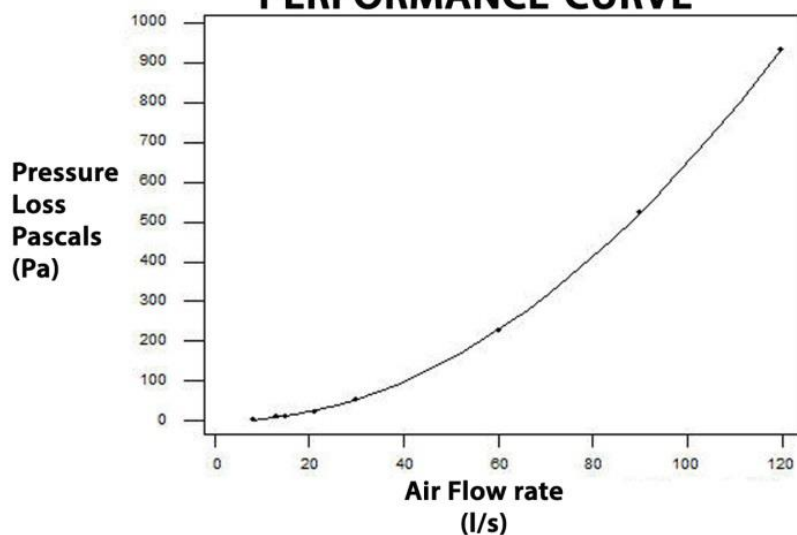

*Pressure losses with Control Disk 10mm open

Associated Ancillaries



| AIRFLOW | RESISTANCE |
|---------|------------|
| 8 l/s | 5.00 pa |
| 13 l/s | 10.00 pa |
| 21 l/s | 22.80 pa |
| 30 l/s | 53.70 pa |
| 60 l/s | 228.00 pa |
| 120 l/s | 935.00 pa |