

# Integra

Heat Recovery Ventilation unit

Installation and Wiring Instructions



Stock Ref. N°

456864

220-240V~50Hz

**Vent-Axia®**

PLEASE READ INSTRUCTIONS IN CONJUNCTION WITH ILLUSTRATIONS.  
PLEASE SAVE THESE INSTRUCTIONS.



# VENT-AXIA INTEGRA - HEAT RECOVERY VENTILATION UNIT

## INSTALLATION AND MAINTENANCE INSTRUCTIONS

*Read the following instructions in conjunction with the illustrations before commencing installation.*

### IMPORTANT SAFETY INFORMATION

#### **PLEASE READ THESE INSTRUCTIONS CAREFULLY BEFORE COMMENCING INSTALLATION.**

1. Do not install this product in areas where the following may be present or occur:
  - Excessive oil or a grease laden atmosphere.
  - Corrosive or flammable gases, liquids or vapours.
  - Subject to direct water spray from hoses.
  - Ambient temperatures higher than 40°C and lower than -20°C.
  - Possible obstructions that may hinder access to or removal of the unit.
2. All wiring must be in accordance with the current IEE wiring regulations BS7671, or appropriate standards of your country. Installation should be inspected and tested by a suitably qualified person after completion.
3. Ensure the mains supply (voltage, frequency and phase) complies with the rating label.
4. The unit should be provided with a local double pole fused spur fitted with a 3A fuse having a contact separation of at least 3mm.
5. These units must be earthed.
6. Precautions must be taken to avoid the back-flow of gases into the building from the open flue of gas or other fuel-burning appliances.
7. This appliance is not intended for use by persons (including children) with reduced physical, sensory or mental capabilities, or lack of experience and knowledge, unless they have been given supervision or instruction concerning use of the appliance by a person responsible for their safety.
8. Young children should be supervised to ensure that they do not play with the appliance.

### INSTALLATION GUIDANCE

1. The installer is responsible for the installation and electrical connection of the sentinel system on site. It is the responsibility of the installer to ensure that the equipment is safely and securely installed and left only when mechanically and electrically safe.
2. All regulations and requirements must be strictly followed to prevent hazards to life and property, both during and after installation, and during any subsequent servicing and maintenance.
3. The unit's condensate drain must be connected to the building's wastewater drainage system.
4. Certain applications may require the installation of sound attenuation to achieve the sound levels required.
5. The unit must not be connected directly to a tumble drier.
6. The supply and exhaust valves must be fully opened prior to commissioning.
7. The supply air must be drawn from the exterior of the property.
8. The unit should be allowed to stabilise during commissioning for a minimum period of 5 minutes when changing between boost and normal speeds.
9. Ensure that the unit's external grilles are a minimum of 1500mm apart. The exhaust grille should be located at least 600mm away from any flue outlet. The inlet grille should be located 2000mm away from any flue outlet.
10. This product and associated duct installation should be carried out in accordance with the domestic ventilation compliance guide.

### Disposal

This product should not be disposed of with household waste. Please recycle where facilities exist. Check with your local authority for recycling advice.

## PRODUCT DESCRIPTION

The Integra is a void/ loft mounted heat recovery ventilation unit for domestic and commercial applications. It is designed for connection to 100mm-diameter insulated flexible ducting on to rigid ventilation ducting.

The unit's two fans and heat exchanger arrangement simultaneously supply and extract air while transferring heat from the stale exhaust airflow to the fresh intake airflow. This provides up to 70% heat recovery from the stale extracted air.

Separation of the exhaust airflow and intake airflow is maintained throughout the unit.

The fan motors have maintenance free self-lubricating long life bearings and are fitted with thermal overload protection, which in the event of a fault causing a motor to overheat will cut off the electrical supply to that motor.

The electrical power consumption of the unit is 170 watts when running at full speed.

The unit can be controlled by a trickle/ boost switch (455213) (See Fig.2a) or with an ambient response humidity sensor (563550) for humidity control (See Fig. 2b). For maximum controllability we recommend that the 150VA transformer (563538A) is used which enables the selection of trickle settings to match a dwellings volume.(See Fig.2c & Fig.2d) These are available from your local Vent-Axia stockist.

To achieve the stated Energy Efficiency rating the unit should be connected so that it is controlled via two sensors/switches and has 3 running speeds, Fig.2d shows an example of this.

A summer bypass switch (409999) is available (See Fig.3).

## FITTING INSTRUCTIONS

1. Remove the ventilation unit, together with the ceiling hanger kit from the packaging.
2. After noting the positions of the duct spigots, cable and drainage connection on the ventilation unit (see Fig. 1). Select a suitable installation site and type. Note that the unit must be mounted with the drainage at the bottom (2-degree tilt towards the drain). The site selected must allow sufficient space around the unit for the removal of the ducts, cover and heat exchanger for maintenance and servicing purposes.
3. If appropriate, provide mains electrical supply and drainage system in the vicinity of the installation site.
4. Typically there are three forms of installation for the Integra.

**To mount the unit on joists:** Place the unit across two beams and attach the appropriate cabling, drainage and ductwork to the unit, with the Vent-Axia logo facing up. For optimum performance, ensure the ductwork does not turn 90deg directly off the spigots. The unit should, for optimum drainage, be tilted by 2 degrees towards the drain side. See Fig. 1a.

**To suspend the unit from rafters:** Use the kit 456428 four strap-hangers and mounting channels. Attach four hooks to the joists then attach the mounting channels to the base of the unit with the 4 screws & washers provided then attach the strap-hangers onto the channel fixing holes. With the Vent-Axia logo facing down, lift by the strap-hangers and hang on the hooks on the joists in a horizontal position. The unit should, for optimum drainage, be tilted by 2 degrees towards the drain side. See Fig. 1b.

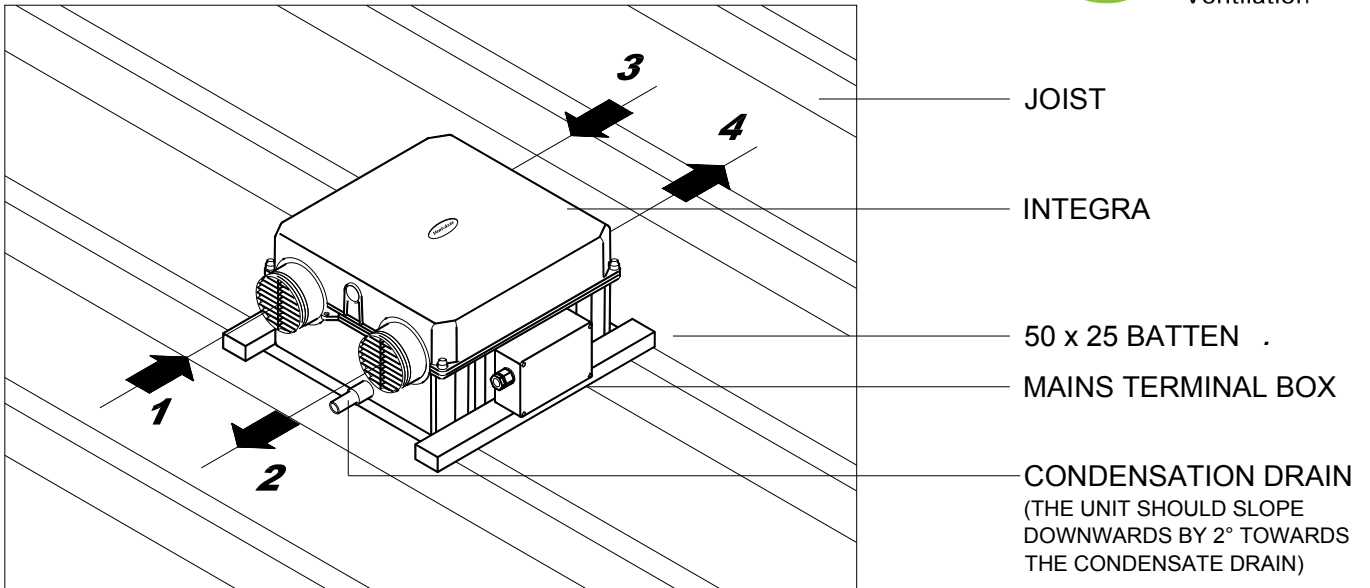
**To suspend the unit in a ceiling void:** Use the kit 456428 four strap-hangers and mounting channels. Attach four hooks to ceiling structure then attach the mounting channels to the base of the unit with the 4 screws & washers provided then attach the strap-hangers onto the channel fixing holes. With the Vent-Axia logo facing down, lift by the strap-hangers and hang onto the hooks on the ceiling structure in a horizontal position. The unit should, for optimum drainage, be tilted by 2 degrees towards the drain side. See Fig. 1c.

**Please note - the situation and type of installation for the unit must be decided and assembled before any drainage knockouts are removed, as they cannot be refitted.**

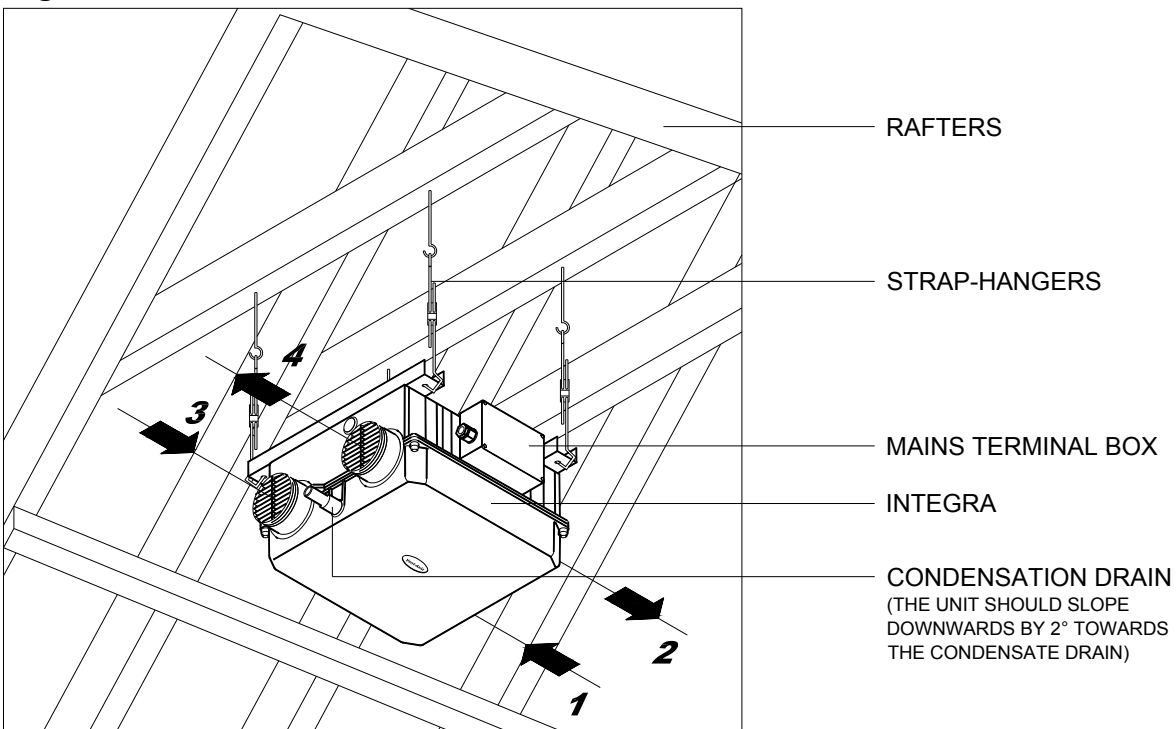
5. Having decided upon a location and position remove the knock out for the condensate drain, this must be at the lowest point. Connect the drain of the ventilation unit to the drainage system.
6. Install suitable internal and external grilles/ terminals and connect them to the ventilation unit using suitable 100mm ducting. If flexible ducting is used, it should be stretched in order to obtain the best performance.

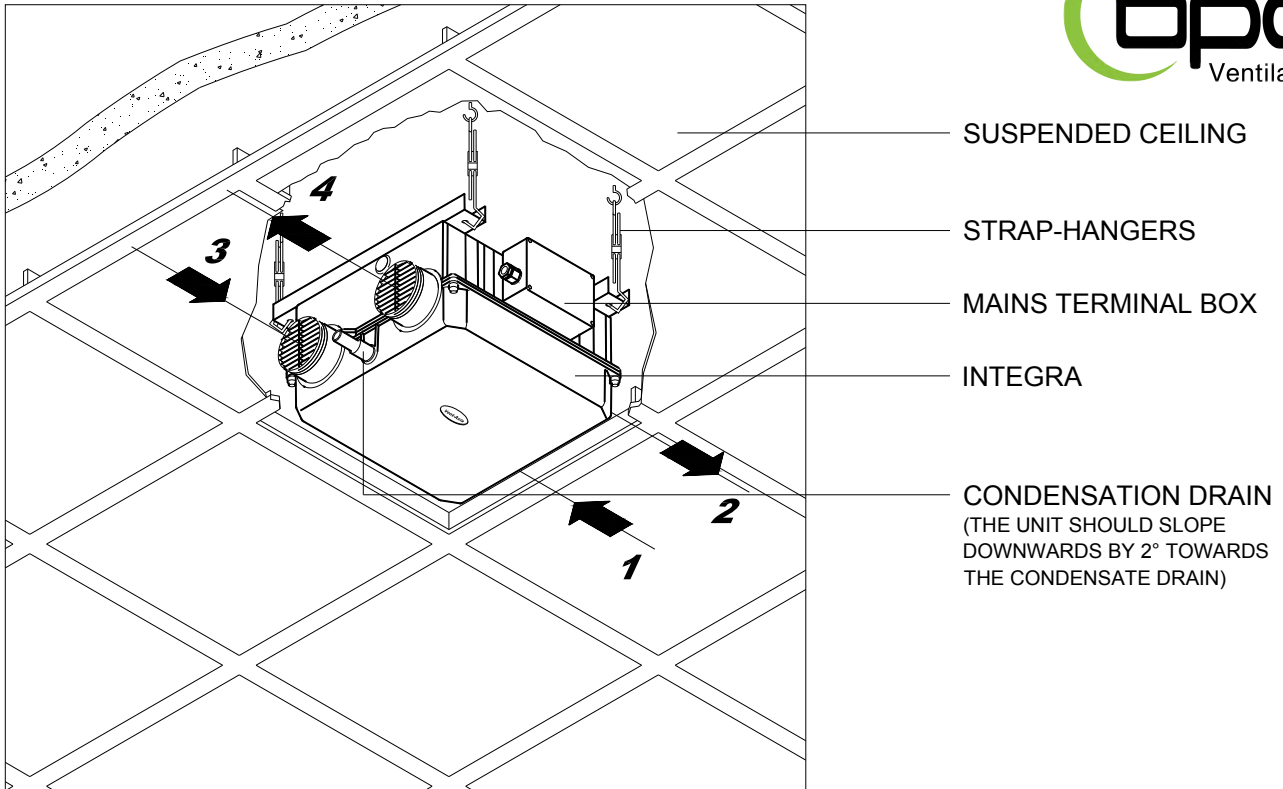
# MOUNTING OPTIONS

**Fig. 1a. MOUNTED ON JOISTS**



**Fig. 1b. SUSPENDED FROM RAFTERS**

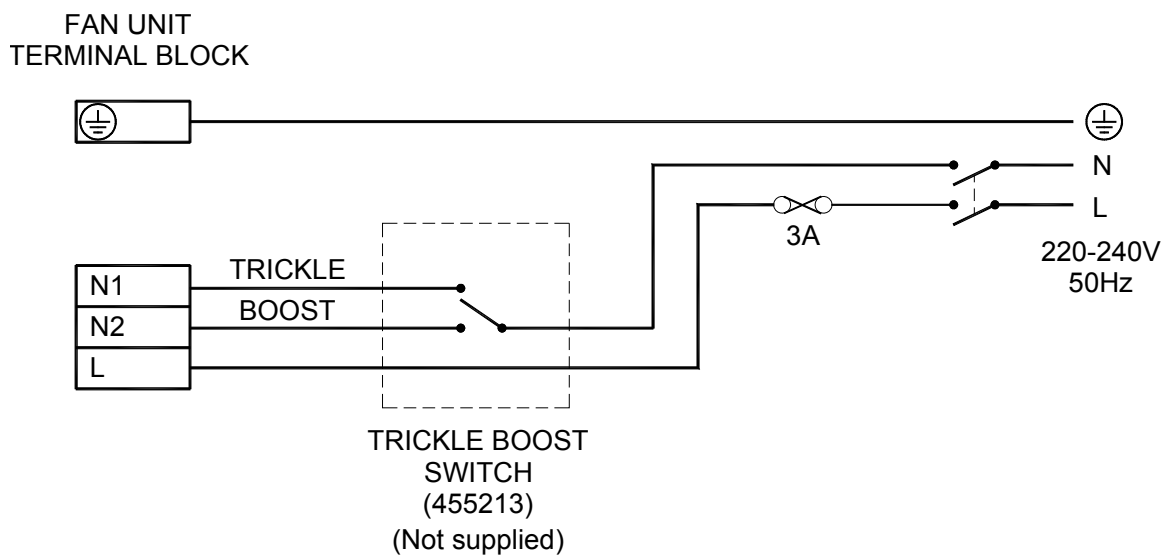




**Fig. 1b. SUSPENDED IN ROOF VOID**

- 1. Stale exhaust air from inside**
- 2. Fresh intake air to inside**
- 3. Fresh intake air from outside**
- 4. Stale exhaust air to outside**

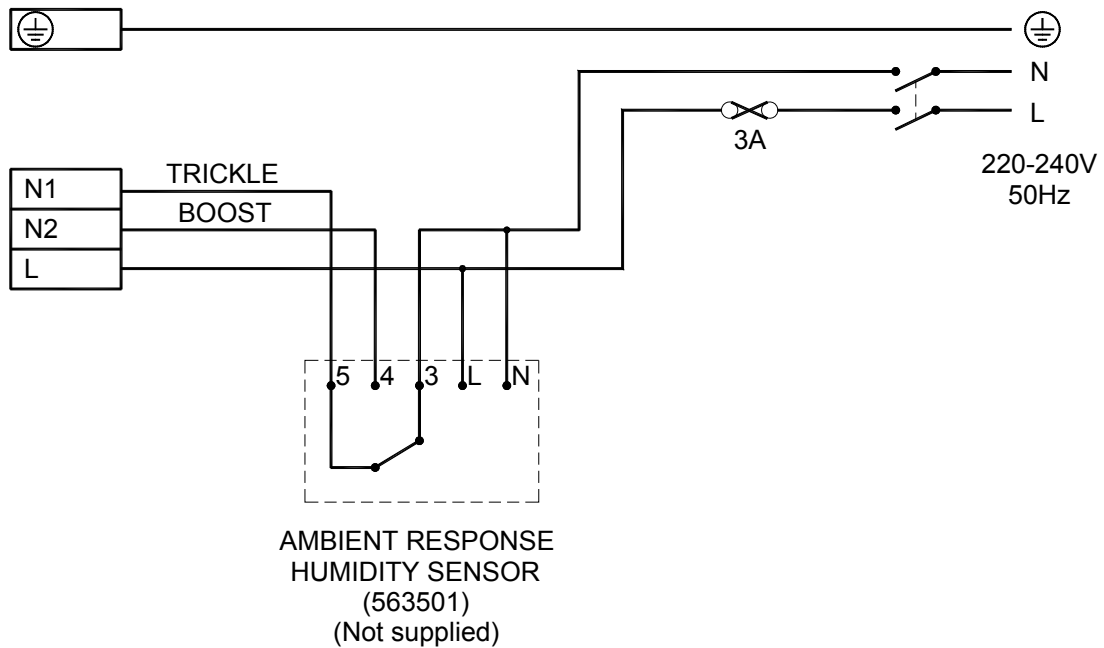
**Fig.2a (Integra operated by a Trickle/Boost switch)**



**Fig.2b (Integra operated by an Ambient Response humidity sensor)**



FAN UNIT  
TERMINAL BLOCK



**Fig.2c (Integra Controlled by a single Trickle/Boost switch via a 150VA transformer)**

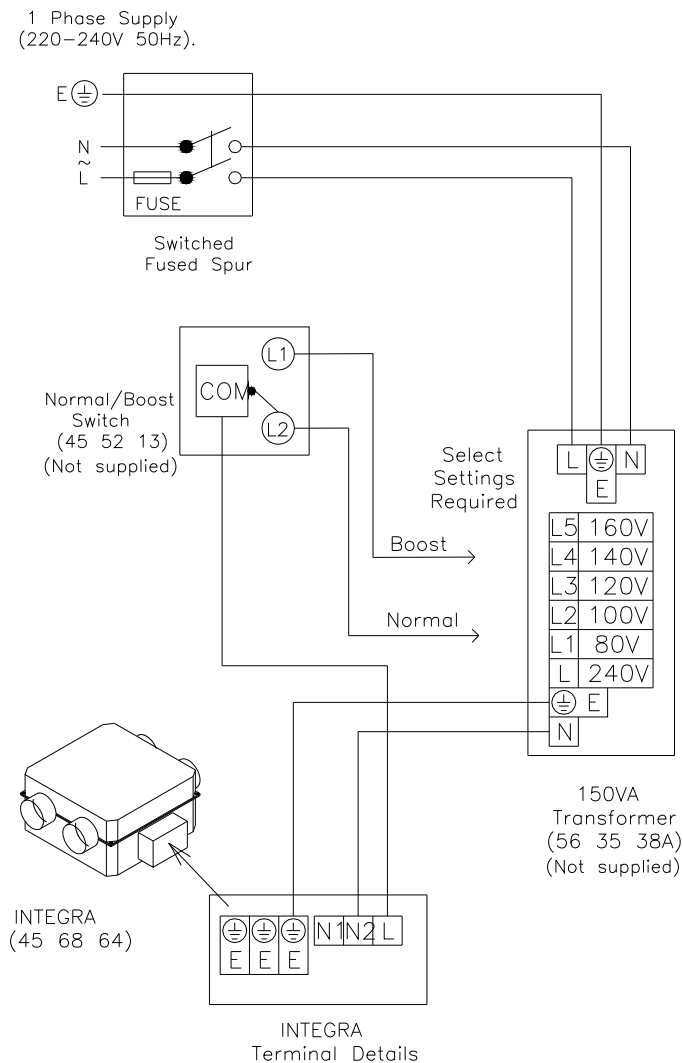
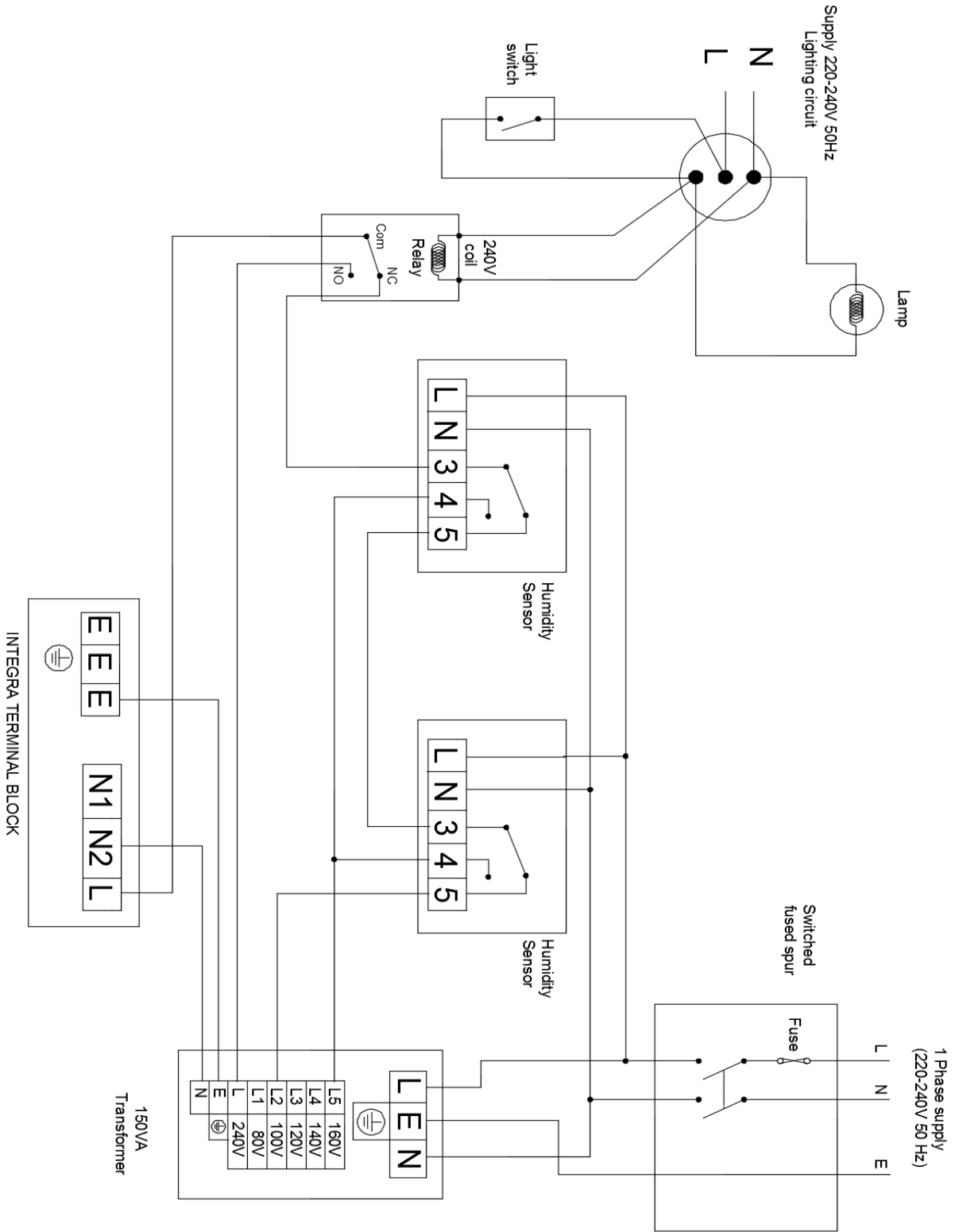
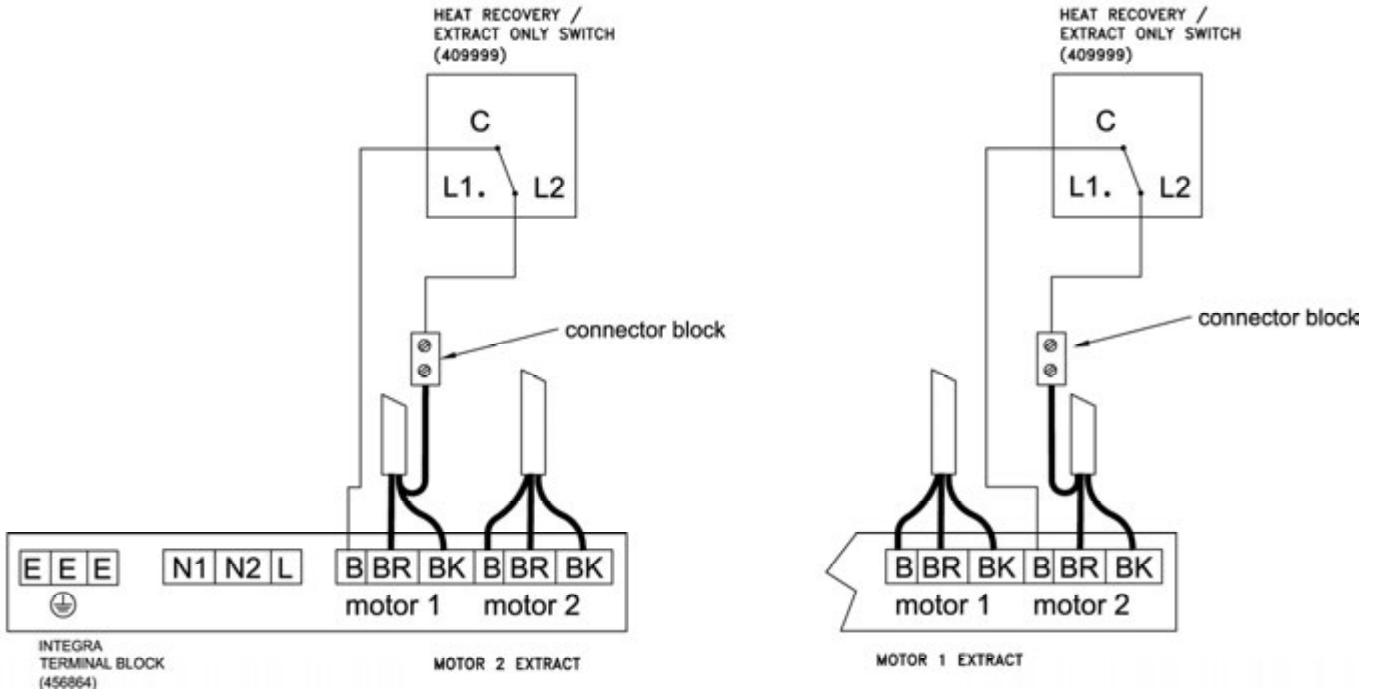


Fig.2d (Integra controlled via two sensors/switches and a 150VA transformer to give 3 running speeds).



**Fig.3 Summer Bypass/ Extract Only Switch (409999 NOT supplied)**



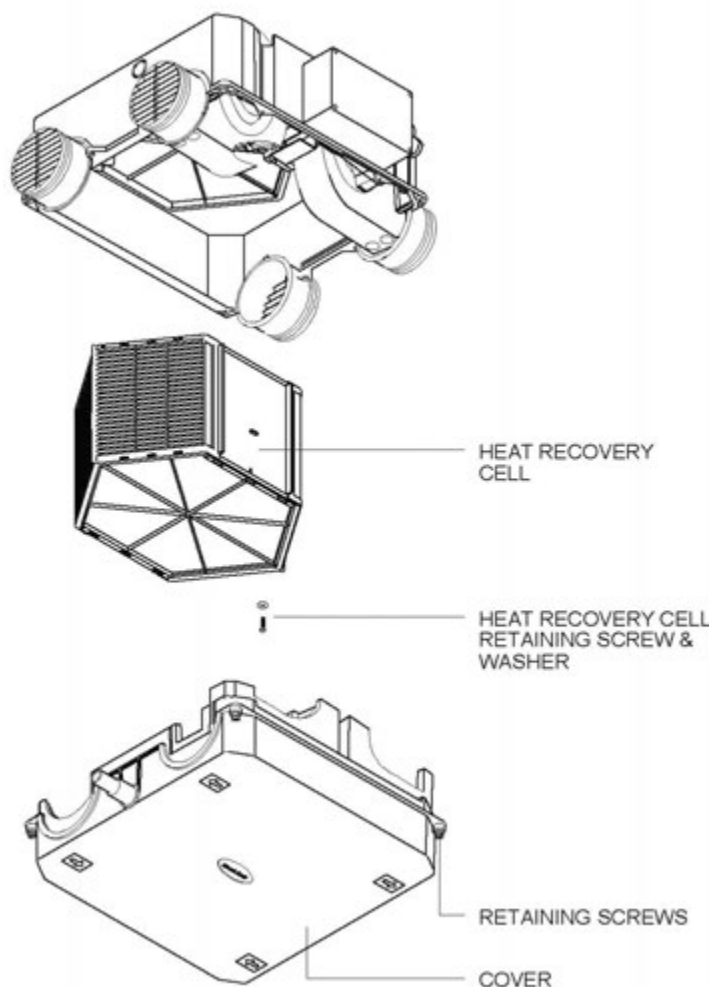
Where an extract only switch is to be used the blue wire for the **supply** motor needs to be connected to the switch as shown. The L, N1, N2 and E terminals should be connected as per the relevant Fig.2. After installation ensure that with the switch set to extract only that there is no supply airflow.

Note: If the summer bypass is used **without** the 150VA transformer the unit will run at boost in trickle and boost setting.



## CLEANING INSTRUCTIONS

(Cleaning to be carried out by a competent qualified person)



Apart from removing odours, providing fresh air and recovering heat, this unit extracts airborne impurities such as dust, dirt and grease. These gradually build up and detract from the efficiency of the unit. Therefore, to ensure peak performance, the unit should be cleaned regularly at intervals determined by the level of contamination experienced to the following procedure: (Fig.3).

1. Switch off the mains electrical supply to the unit.
2. Remove the cover from the unit after releasing the four retaining screws.
3. Unscrew and remove the single screw retaining the heat recovery cell.
4. Withdraw the heat recovery cell.
5. Wash the heat recovery cell in warm water using a mild detergent then ensure that it is thoroughly dried.  
NOTE: Keep water away from all electrical components and wiring inside and outside the unit. There may be some condensation present in the cell. Remove carefully and avoid tilting as the cell retains some water.
6. Replace the heat recovery cell in the direction of the arrow.
7. Replace the cover and secure with the retaining screws.
8. Switch on the mains power supply and check for satisfactory fan operation.

## PRODUCT FICHE

For Residential Ventilation Units (Complying Commission Delegated Regulation (EU)  
No 1254/2014)

Name:	Vent-Axia
Model ID (Stock Ref.) :	Integra - 456864 - LDC
SEC Class	C
SEC Value ('Average')	-23.79
SEC Value ('Warm')	-1.93
SEC Value ('Cold')	-62.73
Label Required? (Yes/No=Out of scope)	Yes
Declared as: RVU or NRVU/UVU or BVU	RVU/BVU
Speed Drive	Multi-Speed
Type HRS (Recuperative, Regenerative, None)	Recuperative
Thermal Eff: [ (%), NA(if none)]	60.00
Max. Flow Rate (m3/h)	115.20
Max. Power Input (W): (@Max.Flow Rate)	182.00
LWA: Sound Power Level (dB)	51.53
Ref. Flow Rate (m3/s)	0.02
Ref. Pressure Diff. (Pa)	120
SPI [W/(m3/h)]	1
Control Factor & Control Typology: (CTRL/ Typology)	
Control Factor; CTRL	0.65
Control Typology	Local Demand Control
Declared: -Max Internal & External Leakage Rates(%) for BVUs or carry over (for regenerative heat exchangers only), -&Ext. Leakage Rates (%) for Ducted UVUs;	<5% Internal, <5% External
Mixing Rate of Non-Ducted BVUs not intended to be equipped with one duct connection on either supply or extract air side;	N/A
Position and description of visual filter warning for RVUs intended for use with filters, including text pointing out the importance of regular filter changes for performance and energy efficiency of the unit	N/A
For UVUs (Instructions Install Regulated Supply/Extract Grilles Façade)	N/A
Internet Address (for Disassembly Instructions)	www.vent-axia.com
Sensitivity p. Variation@+20/-20 Pa: (for Non-Ducted VUs)	N./A
Air Tightness-ID/OD-(m3/h) (for Non-Ducted VUs)	N./A
Annual Electricity Consumption: AEC (kWh/a)	7.04
Annual Heating Saved: AHS (kWh/a)	
AHS: Average	40.72
AHS: Warm	18.41
AHS: Cold	79.66



## The **Vent-Axia** Guarantee

Applicable only to products installed and used in the United Kingdom. For details of guarantee outside the United Kingdom contact your local supplier.

Vent-Axia guarantees its products for two years from date of purchase against faulty material or workmanship. In the event of any part being found to be defective, the product will be repaired, or at the Company's option replaced, without charge, provided that the product:-

- Has been installed and used in accordance with the instructions given with each unit.
- Has not been connected to an unsuitable electricity supply. (The correct electricity supply voltage is shown on the product rating label attached to the unit).
- Has not been subjected to misuse, neglect or damage.
- Has not been modified or repaired by any person not authorised by the company.

### IF CLAIMING UNDER TERMS OF GUARANTEE

Please return the complete product, carriage paid to your original supplier or nearest Vent-Axia Centre, by post or personal visit. Please ensure that it is adequately packed and accompanied by a letter clearly marked "Guarantee Claim" stating the nature of the fault and providing evidence of date and source of purchase.

The guarantee is offered to you as an extra benefit, and does not effect your legal rights



# **Vent-Axia**

Head Office: Fleming Way, Crawley, West Sussex, RH10 9YX. Tel: 01293 526062 Fax: 01293 551188

**UK NATIONAL CALL CENTRE**, Newton Road, Crawley, West Sussex, RH10 9JA

SALES ENQUIRIES: Tel: 0344 8560590 Fax: 01293 565169

TECHNICAL SUPPORT: Tel: 0344 8560594 Fax: 01293 532814

Web:- [www.vent-axia.com](http://www.vent-axia.com)

Email:- [info@vent-axia.com](mailto:info@vent-axia.com)

As part of the policy of continuous product improvement Vent-Axia reserves the right to alter specifications without notice.